

## HYDRO MOS®

Mobile reverse osmosis unit

Typ: HAS mobile

### Application

HYDRO MOS® HAS mobile is a compact reverse osmosis unit, designed for the production of low-salt water and to be used independent on the site.

HYDRO MOS® HAS mobile is mainly used for filling up heating- or cooling systems or for producing low-salt water for window cleaning and solar plants.

### Procedure

The HYDRO MOS® HAS mobile reverse osmosis unit works with semi permeable membranes allowing water (H<sub>2</sub>O) to pass the pores, but preventing dissolved materials (ions) from passing.

If a saline solution and pure water are separated with a membrane (semi permeable), pure water flows without any external forces through the membrane into the saline solution, which is diluted by this.

This from nature known process (metabolism of cells) is called osmosis. The process stops once the osmotic pressure of the corresponding solution is achieved an osmotic balance is given.

### Osmosis

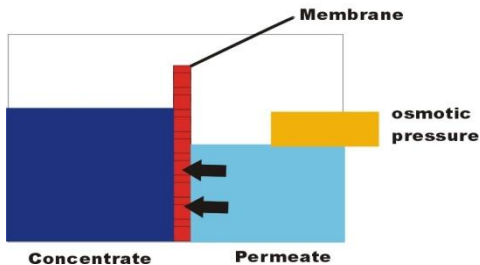

If you reverse this process, by applying more pressure on the higher concentrated solution, clear water flows in reverse direction through the membrane after overcoming the osmotic pressure.

Dissolved salt is retained. Such process is called reverse osmosis

### Reverse osmosis

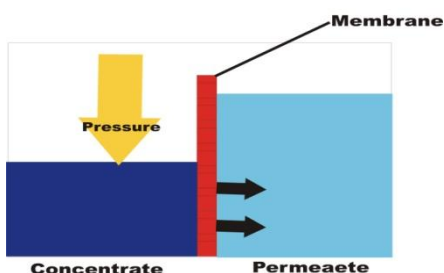

Advantage of reverse osmosis technology compared with other water treatment methods:

- Removal of dissolved salt
- Removal of bacteria and germs
- Retain of particles
- Reduction of dissolved organic materials

## Preparation

The pre-treatment of the water depends on the mains water quality.

The pre-treatment is limited to the scale protection dosage with antiscaling-dosing.

In this way the lifetime of the membranes is extended substantially and significant water save achieved. An additional treatment is necessary, if the iron, manganese or free chlorine values are increased.

## Operation

The feed water is passing the inlet safety filter (50µm), a fine filter (5µm), the intake sluice-for antiscaling dosing and the inlet valve to the high-pressure pump. A pressure switch in front of the pump signals a possible shortage of water pressure.

The water is subsequently guided through the membrane, installed inside the pressure pipe. Clear water (permeate) penetrates the membrane that can be fed to the heating- or cooling systems or be used for cleaning windows or solar plants.

The retained salts are direct lead into the drain as concentrated solution (concentrate). Part of this concentrate is added to the feed water (setting by regulation valve). This concentrate return provides a well streaming of the membrane surface and reduces the wastewater ( savings on operating costs)

The control of the permeate pressure is via the installed pressure switch, which switches off the unit with reaching the set pressure.

The system is designed as a compact unit. Important operating parameters such as:

- Filter pressure
- Operating pressure
- Permeate quality (conductivity)
- Water quantity permeate
- Water quantity concentrate

are shown on the corresponding measuring instruments or the control itself.

## Notes / conditions of installation

- Necessary water quality to be fed to the reverse osmosis unit
  - Total (permanent) hardness < 25 °dH
  - Salinity max. 1.000 mg/l
  - Oxidant (chlorine, chlorine dioxide...) not detectable
  - Iron: < 0,1 mg/l
  - Manganese: < 0,05 mg/l
  - Silicate (SiO<sub>2</sub>): < 15 mg/l
  - Colloidal-Index < 3
  - Turbidity < 1 NTU
  - pH-range: 3 – 9
- Technical data and general technical standards as well as the local installation conditions are to be guaranteed.
- According to DIN 1988 part 4, there has to be a safeguarding against recirculation. (system separation)
- For protection against unwanted incoming materials from the previous connected pipeline network, there has to be installed a fine filter generally.
- The ambient temperature and possibly the radiation heat may not exceed 40°C.
- The place of installation has to be frost free.
- The installation site has to be free from solvent, color, lacquer, and chemical fumes.
- A plug with protection contact (230V / 50Hz) shall be provided next to the system.
- For drainage of wash water, there has to be a channel connection (minimum DN 50)
- The reverse osmosis unit should be set up on flat, solid ground.
- Any lifting appliance shall be resistant to salt water (conveying capacity > 100 l/h).
- To avoid flooding by leakage, the place of installation should have a floor drain or a leakage control with suitable alert.

## Description:

HYDRO **MOS**<sup>®</sup> - HAS mobile reverse osmosis unit consisting of:

- **hand-cart with pneumatic tires**, painted steel with mounting frame of anodized aluminum profiles and plastic front plate- to support the operating- and display elements.
- **Prefilter** with 50µm filter cartridge
- **Fine filter** with 5µm filter cartridge
- **Intake sluice** for antiscaling-dosing
- **high-pressure pump** as blocking valve pump
- **High-Performance wound module** with PA/PS-Composite membranes in GRP-pressure pipe with inliner.
- **fittings** like stop ball cocks for feed water, permeate and concentrate, solenoid valves for feed water and concentrate rejection, stainless steel valves for setting the permeate- and concentrate flow.
- **pressure switch** to control the feed water pressure, system pressure ( permeate outlet)
- **Vibration-damped pressure gauge** for filter- and pump pressure.
- **Water meter** for monitoring the flow rate of permeate and concentrate.

- HYDRO **MOS**<sup>®</sup> - Control

**Micro process control** as described below, unit wired ready for connection.

HYDRO **MOS**<sup>®</sup> - Control for automatically monitoring and controlling of HYDRO **MOS**<sup>®</sup> HAS mobile reverse osmosis with two-line clear text display, for monitoring of:

- **Operating data:** Conductivity of permeate, operating hours
- **Fault signals:** pressure loss, exceed of limited conductivity
- **Operating conditions:** recirculation of concentrate, discontinuous rinse at unit stop.

**Info display:**

removal  
Stand-by  
Rinse  
Interval wash

**Inputs:** (low voltage – 24V DC) for pressure switch feed water ( protection of running dry), pressure switch permeate output

**Outputs:** (230 V / 50 Hz), 2 solenoid valves for feed water and concentrate reject

HYDRO **MOS**<sup>®</sup> is supplied with a detailed manual and electrical wiring plan.

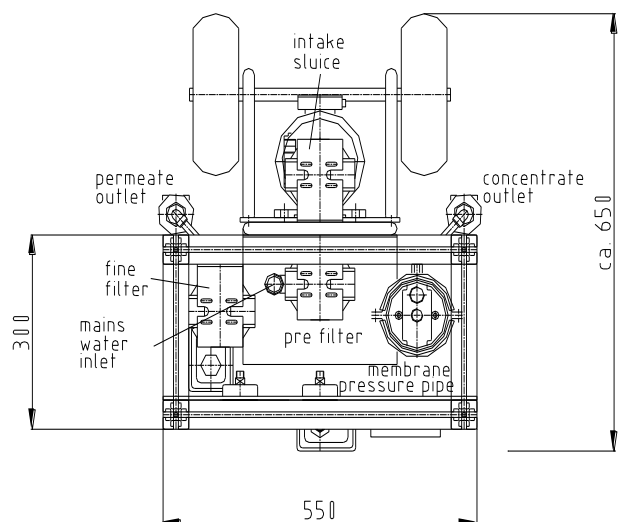
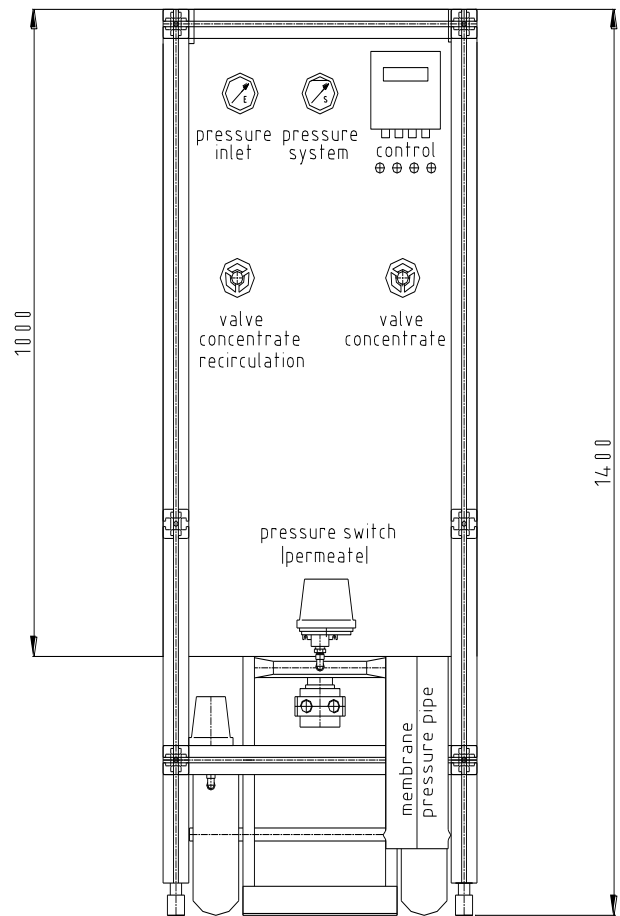

**Technical data:**

Permeate flow rate at 15°C *)	l/h	300
Back pressure maximum	bar	2,5
Min. salt rejection	%	97
Yield (recovery) (factory setting 50%)	%	25 - 75
Operating pressure	bar	14
Membrane element / number		4040 / 1
Feed water volume flow (15°C) at 50% recovery	l/h	600
Concentrate- volume flow (waste water) at 50 % recovery	l/h	300
Mains connection		230 V / 50 Hz
connection	VAC	4
Pre fuse	A	8
Kind of protection		IP 65
Max. total salt content feed water ras NaCl	mg/l	1000
Blocking index / SDI		< 3
pH-value		3 – 11
Feed water connection	DN	25 (1" AG)
Connection permeate	DN	20 (3/4")
Connection concentrate	DN	20 (3/4")
Channel connection (necessary) minimum	DN	50
Measuring range conductivity	µS/cm	1 – 200
Feed water pressure minimum / maximum	bar	2,0 / 6
Feed water temperature minimum / maximum	°C	5 / 35
Ambient temperature	°C	40
<b>dimensions</b>		
Height	mm	1400
width	mm	550
Depth total	mm	650
Operating weight	kg	78

\*) Permeate flow is dependent on the feed water quality (salinity) and also of the inlet pressure, back pressure and recovery

**Example for installation**

